

KD-PHY1000 – Product Brief

Gigabit POF Transceiver



Commercial launch Q3 2012

Features

- ◆ Fully integrated Gigabit POF transceiver
 - ❖ Low cost BOM and simple connectivity with FOTs
 - ❖ Analog interface to the FOTs with built in automatic gain control and filters for reduced system cost
- ◆ First silicon compliant with Gigabit POF Standard⁽¹⁾
 - ❖ Fully compatible with optional annexes, providing Adaptive Bit Rate (ABR) and 100 Mbps Long Reach operations
- ◆ Silicon aimed towards the main POF markets: Home, Industrial and Automotive
- ◆ Advanced DSP and decoding algorithms to provide the highest sensitivity
 - ❖ Up to -21 dBm (ER > 10 dB) for 1 Gbps at 50 m SI-POF (IEC 60793-2-40 A4a.2) using red LED
 - ❖ Up to -34 dBm (ER > 10 dB) for 100 Mbps at 150 m SI-POF using red LED
- ◆ Silicon designed for any type of large core optical fiber
 - ❖ Support for SI-POF, MI-POF, MC-POF, GI-POF, PCS, etc.
 - ❖ Adaptive equalization and coding to provide maximum link budget and bit-rate in any optical link
- ◆ Open and flexible Ethernet interfaces: MII, GMII, RGMII, SGMII, SerDes and RTBI
 - ❖ Easy connectivity to any Ethernet MAC or PHY
 - ❖ PCB design simplification: reduced I/O pin requirements with RGMII (over 50%), SGMII (over 75%), SerDes (over 80%)
- ◆ Support for Jumbo packets up to 10 KB
- ◆ Raw video parallel interface and SPI/I²C control interfaces
 - ❖ Direct connection of video cameras and ECUs for ADAS applications developed in the automotive industry
- ◆ Designed to be used with current off-the-shelf optoelectronics
 - ❖ RCLED, LED and PIN PD currently used in 100 Mbps products
 - ❖ Built in advanced and adaptive digital algorithms for non-linear compensation of RC/LED harmonic distortion
- ◆ 802.3 100base-FX backward compatibility for legacy installations
- ◆ Based on the reliable and short time-to-market ASIC architecture developed by KDPOF
 - ❖ Custom Digital Signal Processor based on Transport Triggered Architecture (TTA), optimized for adaptive filtering
- ◆ 65nm CMOS process
- ◆ Small area
 - ❖ Low cost
 - ❖ Integrable with optoelectronics in a single optical package
- ◆ Low power:
 - ❖ Less than 250 mW per port (w/o optoelectronics)
 - ❖ Advanced power management
 - ❖ Compliant with Gigabit POF Standard low power modes
 - ❖ Requires no airflow or heat-sink
- ◆ On-chip voltage regulators
- ◆ IEEE 1149.1 (JTAG) boundary scan for easy manufacturing
- ◆ Available in 64-pin QFN package or bare-die

(1) Standard developed under the coordination of VDE/DKE WG 412.7.1. This will be delivered at 2012 as an IEC norm.

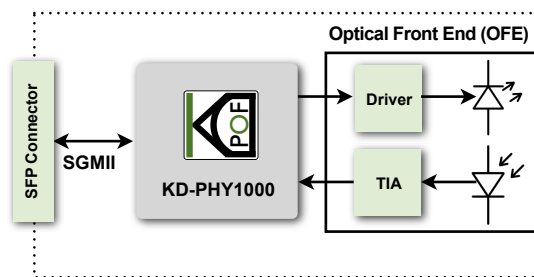

Gigabit POF SFP/GBIC Module

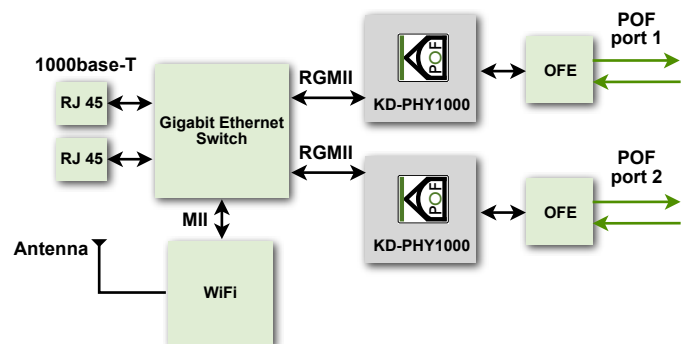

Network node (e.g. wall plug) with POF daisy-chain topology support, that offers external 1000base-T and WiFi connectivities



Knowledge Development for POF[®]

"approaching the Shannon limit"

Overview

The KD-PHY1000 is a fully integrated Gigabit transceiver, optimized for low power and small footprint size. The KD-PHY1000 incorporates the leading edge digital communication technology developed by KDPOF. The KDPOF technology incorporates the most advanced techniques in spectrally efficient coded modulations, adaptive non-linear equalization and adaptive bit-rate, never used before in optical fiber communications. The KDPOF technology is able to reach a performance very close to the Shannon limit, increasing both the bit-rate and the coverage over any large core optical fiber as SI-POF, MC-POF or PCS.

The optimal 65 nm CMOS process offers the best performance, lowest cost, and lowest power for Gigabit POF solutions. Further, devices based on the 65 nm process offer an excellent long-term cost curve, enabling better cost reduction over time compared to older technologies.

The KD-PHY1000 is designed to fulfill the requirements of the main POF markets: Home Networking, Automotive and Industrial. The KD-PHY1000 is available in small footprint 64-QFN package as well as in bare-die. The last option enables integration of KD-PHY1000 with optoelectronics in a single optical package, reducing the size of the POF port. Further, by using the SerDes interface, the POF port offers the same connectivity that any IEEE 802.3™ 1000base-X device (i.e. 1.25 Gbps with 8b/10b NRZ line code) or 100base-X (i.e. 125 Mbps with 4b/5b NRZI line code).

Home and Small Office are two of the key applications for the future POF networking development. The KD-PHY1000 ASIC is the perfect device to integrate Gigabit capabilities in POF ports. Further, the wide range of supported MAC and PHY Ethernet interfaces simplifies the system and board level designs.

Examples of products able to incorporate POF ports based on KD-PHY1000 are Set Top Boxes, Routers, Digital TVs, Network

attached Drives, as well as network components like switches, wall plugs and media converters (e.g. POF-to-Copper).

Both point-to-point and daisy-chain topologies are possible with KD-PHY1000. The implementation of network nodes, like wall plugs incorporating several POF ports for daisy-chain topology, is highly simplified thanks to the flexible interfaces: MII, GMII, RGMII, SGMII and SerDes MAC. On the other hand, KD-PHY1000 allows backwards compatibility with POF ports based on IEEE 802.3 100base-FX, enabling connectivity in legacy installations.

The KD-PHY1000 is also well suited to fulfill the industrial market requirements. The performance provided by KDPOF technology under industrial power budget requirements extends the reach of PROFINET and other field buses from the actual limits up to more than 150 meters, running at 100 Mbps. KD-PHY1000 is suitable for integration in 9x1 and SFP packages, and ensures a smooth backwards compatibility with current equipments and systems.

It has been already several years since the automotive industry incorporated POF in cars. With the growing demand for automotive safety, all the leading OEMs and suppliers are heavily investing in ADAS (Automotive Driving Assistance Systems) technologies. Most of the ADAS implementations are based on a sensor (typically a CMOS or CCD image device), an ECU and a display or any other HMI. The link between all these subsystems is very well suited for POF, running at Gigabit speeds and low latency. The KD-PHY1000 is optimized for ADAS applications by integrating parallel video and SPI/I²C control interfaces as well as an advanced multi-protocol multiplexer. KD-PHY1000 can be integrated in an image based sensor without requiring additional micro-controller, encapsulating transparently the video data and the control signals between the sensor and ECU over a single POF link.

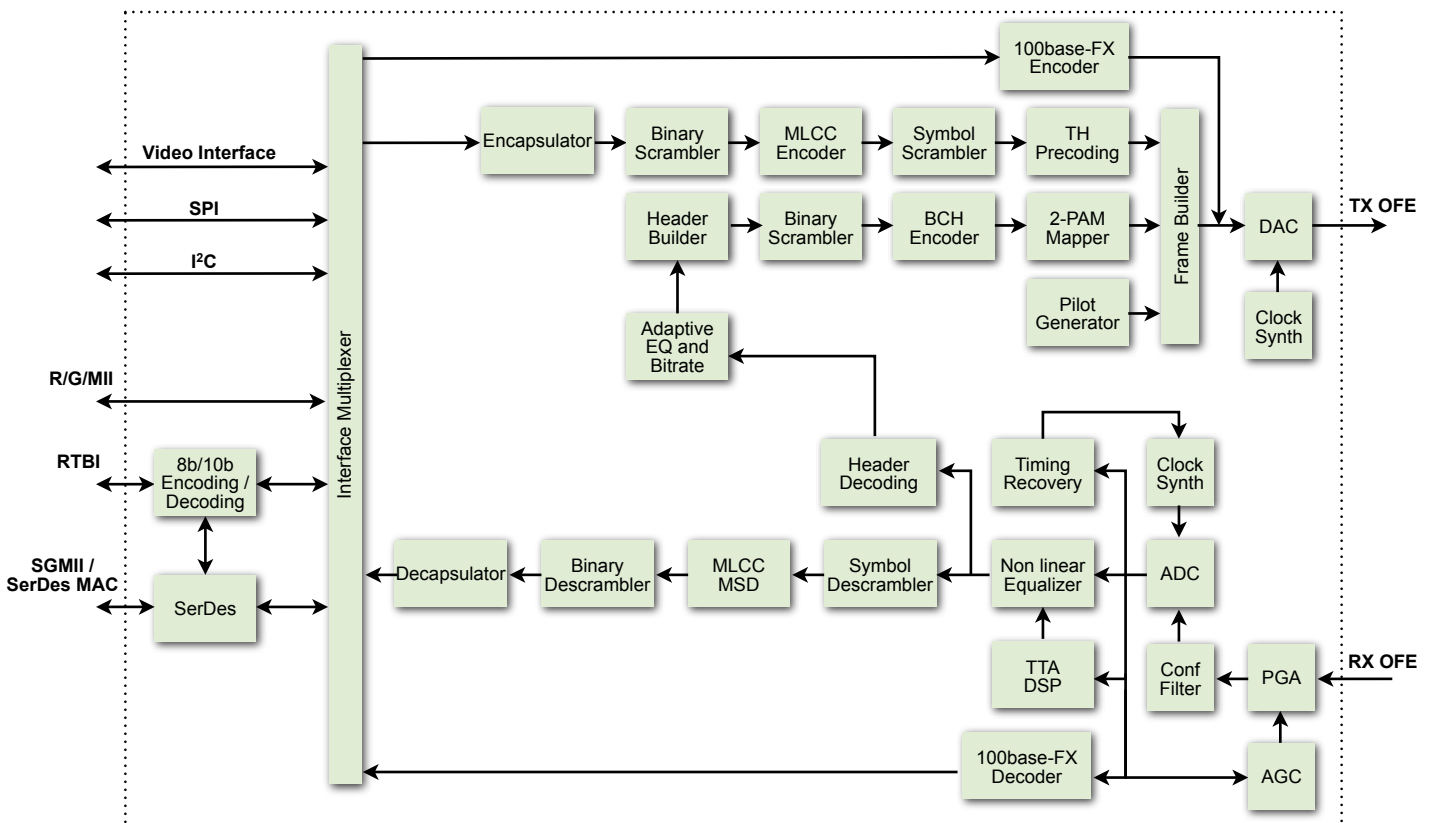

KD-PHY1000 Block Diagram

